

LC-2A



2ch Simultaneous Charger for 7.2V/7.4V Li-ion Battery (Panasonic/Canon/Sony)

Instruction Manual

Thank you for purchasing the LC-2A 7.2V/7.4V 2 channel simultaneous charger. LC-2A is designed to charge Panasonic/Canon/Sony type Lithium ion battery by replacing the battery adaptor. Prior to using the charger, IDX recommends to read this Instruction Manual and keep this manual for future reference.

⚠ WARNING

May cause sudden serious injury and death

- Do not connect to an AC power source that exceeds the voltage specification stated on the unit.
- Use only with the compatible batteries listed in this manual.
- Do not short the contact pins with any metal object.
- Do not carry or store with metal equipment.
- Do not immerse in water.
- Do not attempt to open the outer casing or break apart.
- Do not subject the unit to extreme physical impact or pressure, or place any object across the terminals that could cause it to short.
- Do not attempt to use if damaged.
- Protect the power cord from any damage.

⚠ CAUTION

May cause sudden serious injury and death

- The unit should be used under the conditions listed in this manual.
- Do not expose the unit to extremely high temperatures.
- Use the approved power cord / appliance connector / plug conforming to the properratings (voltage, ampere) and safety regulations of each country if applicable.
- Keep the unit away form excessively dry or humid environments
Stop charging immediately if the charging does not complete within the designated time.
- In case of abnormal smell , leak , color change or case deformity
- during use, turn the power off and unplug the cable from the socket to avoid possible injury.
- This is a class A product in a domestic environment this product may cause radio interference in which case the user may be required to take adequate measures.

Features

- Universal AC input for world-wide use.
- Simultaneous quick charge.
- Auto safety & protection features.
- Can charge Panasonic/Canon/Sony type batteries by exchanging the battery adaptor.
- The charger will automatically turn off when there are no batteries mounted /detected for 1 hour.

Specifications

- Voltage for AC adaptor : 100 - 240V AC, 50/60 Hz Automatic
- AC adaptor : YHY-16003000 (Shenzhen Yinghuiyuan Electronics Co., Ltd)
- Voltage / Power : 12 - 19V DC / 36W max.
- Operating temperature : 0 ~ 40°C / 32 ~ 104°F
- Charging method : Constant ameporage and constant voltage
- Charging current : 1.9A min.
- Protection circuit : Low voltage charging, Quick charging protection
- Dimensions : 125(W)×40(H)×111(D)mm
/4.92(W)×1.57(H)×4.37(D) inches
- Weight : approx. 190g / 0.42lbs (w/o AC adapter and cable)
- Accessories : Panasonic type (PS x2 / P x2)
Canon type x2 (C x2 / CE x2), Sony type (S x2)

Location and function of parts

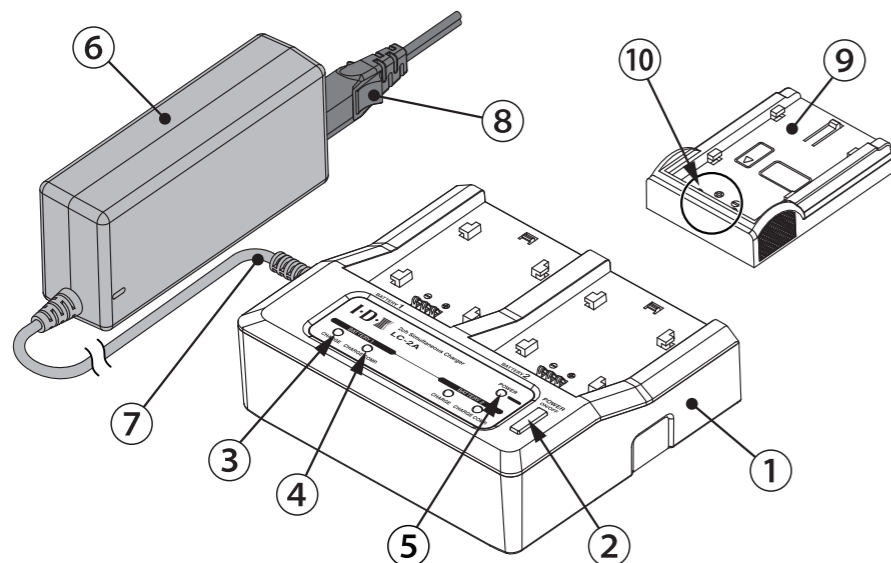

- 1 Charger body
- 2 Power button
- 3 Charge LED (CHARGE)
- 4 Charge complite LED (CHARGE COMP.)
- 5 Power LED (POWER)
- 6 AC adaptor
- 7 DC plug / DC cable
- 8 AC plug / Power cord
- 9 Battery adaptor
- 10 Charging connector

Recommended Battery (as of 2021)

Battery Adaptor type	Label	Recommended Battery
Panasonic (Secured)	PS	● IDX Li-ion battery : SSL-VBG50 ● Panasonic Li-ion battery : VW-VBG6, VW-VBG260, AG-BPS581, CGA-E/625(VW-VBG130 is not compatible with this charger)
Panasonic (Non Secured)	P	● IDX Li-ion battery : SL-VBD50, SL-VBD64, SL-VBD96 ● Panasonic Li-ion battery : VW-VBD55, VW-VBD58, AG-VBR59, AG-VBR89G, AG-VBR118G
Canon	C	● Canon Li-ion battery : BP-955, BP-975
	CE	● Canon Li-ion battery : LP-E6, LP-E6N
Sony	S	● IDX Li-ion battery : SL-F50, SL-F70
		● Sony Li-ion battery : L series, M series

Operating instructions

① Set the Battery Adaptor

- 1: Install your choice of battery adaptor as shown.
※Please attach two adaptor.

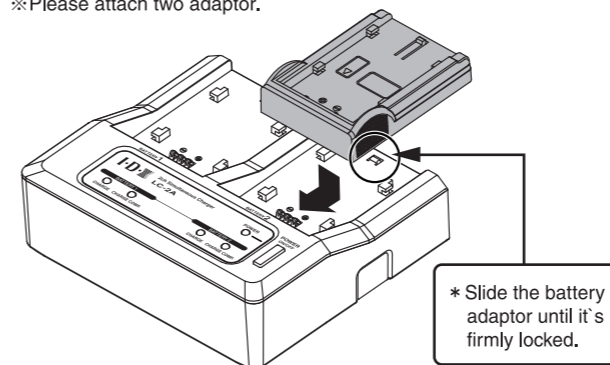

※Can simultaneously charge different battery types.

② Connect the AC Adaptor

- 1: Connect the DC plug to the charger.

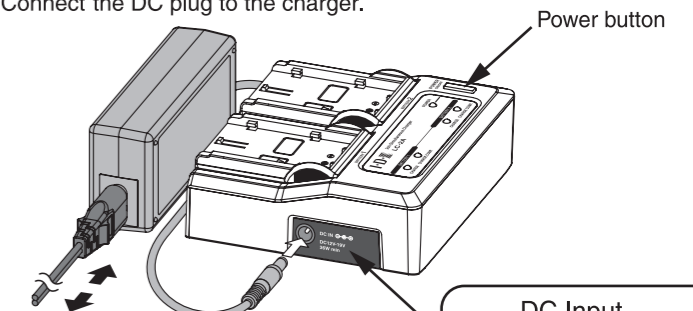

- 2: Power will turn ON as soon as AC and DC connectors are firmly plugged. Please turn ON the Power button.

※LED will light Amber when set to ON.

DC Input



③ Mounting and Removing battery

- 1: Install the battery as shown.
 - 2: When the battery pack is set, a status LED will turn ON. If the condition of the battery is OK, charging will automatically start.
 - 3: Slide the battery back and remove from the battery adaptor.
- ※To prevent the battery adaptor from sliding off, hold in place while removing batteries.
- 4: Please turn the power off when charging is finished.

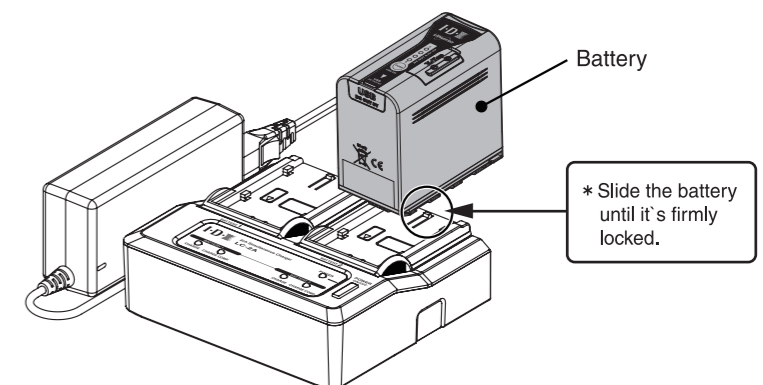

④ Status LED indicator

- 1: When the battery pack is set, the status LED will turn ON. If the condition of the battery is OK, the charge LED will turn solid red and start charging. If the charger detects a fault, the LED will flash red and stop charging.

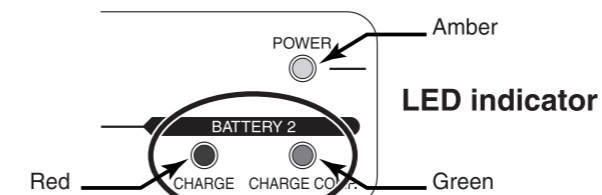

- 2: Charging will automatically stop when the battery is fully charged.

LED indicator states

LED	Indication	Status
POWER LED	Solid Amber	Power ON / Rechargeable state
CHARGE LED	Solid Red	Quick charge in progress
	Flashing Red	When a battery fault is detected on Battery 1 or Battery2, the charger will stop charging and the CHARGE LED will flash RED
CHARGE COMP. LED	Solid Green	Fully Charged
POWER & CHARGE LED	Flashing Amber	When the charger detects an abnormality, charging will stop and three LEDs will flash simultaneously [1x Amber (POWER LED) and 2x Red (CHARGE LED: Battery1 & 2)]
	Flashing Red	

