

Imicro-50P/Imicro-98P/Imicro-150P

Li-ion V-Mount Battery



Instruction Manual



Thank you for purchasing the Imicro-50P / Imicro-98P / Imicro-150P Li-ion V-Mount Battery. Prior to using the Imicro-50P / Imicro-98P / Imicro-150P, we strongly recommend reading this Instruction Manual on how to best use the Imicro-50P / Imicro-98P / Imicro-150P . Please keep this manual for your reference. If you have any additional questions, please contact your local IDX office listed at the end of this manual.

⚠ Important

- Recharge immediately after purchase.
- Please remove the cable after using the USB.
- Do not charge while discharging or discharge during charging. It may cause the connected equipment to stop working, malfunction, or cause significant deterioration.
- Do not use this battery with the following equipment. It may cause significant damage. Power Base Station: EB-2 / EB-4 / EB-424L
- Do not Powerlink to IPL-98 / IPL-150. It may cause significant damage to the battery and any equipment connected to.
- when charging is completed, remove the battery from the charger immediately to avoid discharge.
- Do not use this battery in series or in parallel connection. It may cause significant damage to the battery and any equipment connected to.
- Battery will be delivered in Factory mode (no LED's illuminated). Charging the battery deactivates the factory mode and can be used as normal. *Please refer the LED display setting for more detail.
- When using USB PD, the surface of the main unit may become hot depending on the temperature and the rating of the devices. *Please refer the Protection circuitry section for more detail.

Caution for safety use

Improper handling of this Li-ion battery may result in smoke, heat, fire, explosion or leakage as well as cause performance degradation or failure. Please be sure to observe the following precautions.

⚠ DANGER

May cause sudden serious injury and death.

- Charge with IDX battery charger only.
- Use with professional video cameras or other video equipment. Please contact IDX for more information.
- Do not short the contact pins with any metal object. Do not carry or store with metal equipment.
- Do not expose to heat and never throw the battery in a fire.
- Do not immerse in water. Keep the battery dry and away from excessively dry or humid environments.
- Do not leave the battery exposed to excessive heat such as in a car or directly under the sun light. Do not use outside of specified temperature ranges.
- Do not solder on the contact pins directly.
- Do not attempt to open the outer casing or break apart the battery.
- Do not subject the unit to extreme physical impact or pressure, or place any object across the terminals that could cause it to short.
- Do not pierce or drill into the outer casing of the unit.
- Do not attempt to use the battery if damaged.
- Do not use the battery in a corrosive environment. Damages occur from salt water, seawater, acid, alkali, corrosive gas, etc.
- Risk of explosion if battery cells are replaced by an incorrect type.

⚠ WARNING

May cause serious injury and death.

- Please note that the outside casing becomes hot when the battery is discharged in high temperatures or with high loads.
- Stop charging immediately if the battery fails to charge within the designated time. Refer to charger manuals for charge times.
- Do not use if the battery displays unusual characteristics (odd odor, discoloration, etc.) when in use, during charge or in storage.
- Keep away from fire if the battery leaks fluid or has an unusual smell.
- In case of leakage immediately wash your hands and face thoroughly with clean water and contact your IDX representative for further instructions.
- Immediately seek medical attention if battery fluid gets into contact with your eyes.

⚠ CAUTION

May cause injury or damage other equipment.

- Follow instructions on charging and discharging.
- Store in cool and dry conditions.
- During long periods of inactivity, please remove the battery from the equipment.
- Do not use, store or place the battery in an electrostatic area.
- Always keep the connectors clean.

Features

- Light weight, compact, high performance Li-ion battery with a durable design.
- Five power status LED indicators accurately display remaining power capacity. [Refer to Capacity display LEDs]
- DC output connectors for peripheral equipments. [Refer to D-Tap]
- USB-C connection for power output as well as USB PD charging. [Refer to USB]
- Equipped with V-Torch (LED Light) for universal purpose. (light for approx. ten seconds) [Refer to V-Torch]
- IB mode can be configured. [Refer to IB Setting]
- Fitted with battery deterioration indicator. [Cell Life Indicator]

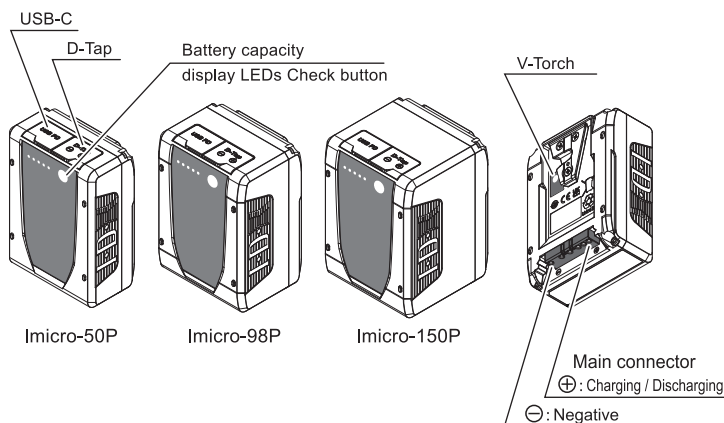

Discharging

- The maximum discharge current is specified below for the main connector, D-Tap and USB, check prior to connecting to equipment the requirements. If it exceeds the maximum discharge power, the safety protection function may be activated and it will stop discharging and may cause damage to the battery. If the fuse is blown due to an over load, the battery won't recover.
- The battery life may diminish if high loads are applied frequently.
- Battery run-time may reduce when used in extreme high and low temperatures. IDX highly recommends to use the battery in ambient temperatures of 50~104°F (10°C~40°C)
- The discharge characteristics of lithium ion batteries illustrate a steady curve until 13V. At 13V, the discharge curve sharply drops. For this reason, IDX recommends setting the camera's "Low Voltage" alarm settings to 13~13.5V. Refer to battery settings on the camera's user manual.
- The battery will automatically stop discharging when the voltage reaches 11V. To extend battery life, IDX recommends to stop using before the battery reaches 12V.
- Microwave transmitters with 5W outputs or more should be kept as far away from the battery as possible. High power transmitters may disrupt or stop supplying power.
- Please be sure to remove the battery from the device after use. If a battery is left mounted on the device that has large standby power, the battery's residual capacity will become lower and the over-discharge protection may be activated.
- Do not use this battery in series or in parallel connection. It may cause significant damage to the battery and any equipment connected to.
- All 5 LEDs flash when the internal temperature gets too high, or when high current or high power is in use.

Charging

- Only charge with an IDX lithium ion charger and refrain from charging with third party chargers. Please refer to the charger manual for charging method information.
- Estimated charging times may vary depending on the charger and condition of the battery. Refer to our website for more details.
- The ambient temperature range for charging is 32~104°F (0~40°C); however, 50~86°F(10~30°C) is recommended for optimizing the charging performance. When the battery is charged in temperatures 32°F(0°C) or below, it may not fully charge, even if the designated charge time has elapsed.
- Charging outside of the recommended temperature range can accelerate cell deterioration.
- Lithium ion batteries have a slight self discharge; therefore, IDX recommends to charge prior to use.
* Refer to [USB] on this manual for charging with the USB-C terminal.
- The standard charge current of the Imicro-50P is lower than the Imicro-98P and Imicro-150P. An IDX USB PD charger (such as UC-PD1 etc) is recommended over a V-mount charger if longevity is required.

⚠ CAUTION

● This battery cannot be charged if the internal battery temperature is below 0°C or above 40°C for safety reasons. It is normal to have an internal temperature rise. If charging is started immediately after use with exceeding 40°C, the charger may display an error and charging may not be possible. If the charger is left or stored in temperature above 40°C or below 0°C, the charger may display an error as well and charging may not be possible. Wait for a certain period and charge the battery after the internal temperature of the battery has reached 0°C to 40°C.

* If the internal temperature of the battery is below 32°F(0°C) or exceeds 104°F(40°C), when the battery capacity check button is pressed, the remaining capacity will be displayed with LEDs for 1 second. After that all LEDs will flash 2 times.

Reference time intervals for the internal temperature to drop below 104°F(40°C) following discharge. (Ambient Temperature : approx. 77°F(25°C))

Imicro-50P		Imicro-98P		Imicro-150P	
Discharge load power	Approximate time	Discharge load power	Approximate time	Discharge load power	Approximate time
50W Discharge	25 Minutes	80W Discharge	30 Minutes	105W Discharge	30 Minutes
65W Discharge	35 Minutes	115W Discharge	40 Minutes	136W Discharge	45 Minutes
80W Discharge	45 Minutes	145W Discharge	50 Minutes	154W Discharge	60 Minutes

● This product is capable of supplying power and charging via USB PD. Please note that the surface of the main unit may become hot depending on temperature and the rating of the attached device.

Capacity display LEDs

- When the check button is pressed, the LEDs will light for approximately 2.5 seconds. Remaining capacity is shown with five LEDs.
- This is displayed as 10%, 20%, 30%, 40%, 50%, 60%, 70%, 80% 90%, and 100%.

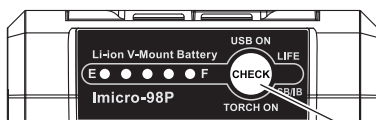

Battery capacity display LEDs check button

● : Solid / ● : Flashing

Capacity	100%	89%	79%	69%	59%	49%	39%	29%	19%	9%
Display	90%	80%	70%	60%	50%	40%	30%	20%	10%	0%
F	●	●	●	●	●	●	●	●	●	●
●	●	●	●	●	●	●	●	●	●	●
●	●	●	●	●	●	●	●	●	●	●
●	●	●	●	●	●	●	●	●	●	●
E	●	●	●	●	●	●	●	●	●	●

● When charging with USB, the current capacity of the following 5 levels is displayed. 5LEDs light off after full charge.

Capacity	100%	99%	59%	39%	19%
Display	100%	60%	40%	20%	0%
F	●	●	●	●	●
●	●	●	●	●	●
●	●	●	●	●	●
●	●	●	●	●	●
E	●	●	●	●	●

⚠ CAUTION

● Charge the battery before use. It is in low power factory mode; the LED does not light up. Charging the battery will deactivate the factory mode and can be used as normal.

Protection circuitry

- There are four types of protection circuits to ensure the battery is protected from Over-charge, Over-discharge, Over-current and Thermal protection. If the fuse is blown, the battery is no longer operable.
- When temperature inside the battery reaches 167°F (75°C), battery stops discharging automatically. Discharge will restart when the inside temperature becomes 140°F (60°C) or less.
- Please charge the battery quickly, if the over-discharge protection is activated. The battery may become unusable, if left without charging.
- If over-current protection is activated, the battery will resume discharging by pressing the remaining capacity check button about one minute after removing the connected device.

⚠ CAUTION

● This product is equipped with a temperature protection function, which may be activated depending on the temperature.

D-Tap

- The maximum D-Tap outputs per port : Imicro-50P @35W / Imicro-98P, Imicro-150P@100W
*Upon usage, please make sure for the maximum discharge load value of the battery. Also please note that the maximum power output of the Imicro-98P is 80W at the temperature of 95~113°F (35~45°C).
- The output voltage is a battery through. (11~16.8V)
- D-Tap output can be used for IDX portable lights and monitors.
- Please do not use D-Tap connectors while charging the battery through the main connector or USB. If you use D-Tap connectors while charging the battery through the main connector, it may cause a charging error or the damage on the charger.

⚠ CAUTION

Please make sure to check the ⊕ ⊖ polarity of D-Tap connector prior to plug-in.

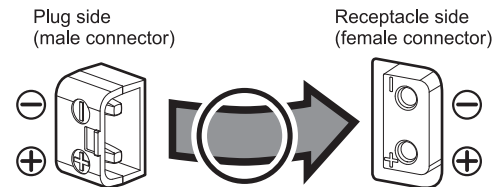

Please confirm the shape of connector and ⊕ ⊖ polarity of plug side prior to connect with receptacle. Please do not force it when felt it is difficulty.

USB

- USB supports PD (Power Delivery), which is capable of maximum 30W for Imicro-50P and 60W power supply and charging for Imicro-98P / Imicro-150P. Be sure to pay attention to the maximum discharging power when power is supplied in combination with battery main connector and D-tap output.
- Please use the Type-C cable that supports PD(Power Delivery) with 3A.
- When connecting a device that does not support USB PD, press down the remaining capacity check button for more than 3 seconds to activate the USB power output. USB power output works automatically when connecting a device that supports USB PD.
- When drawing power from USB PD of the battery, connected device can select voltage and current as below.
Imicro-50P : 5V/3A, 9V/3A, 12V/2.5A, 15V/2A, 20V/1.5A
Imicro-98P / Imicro-150P : 5V/3A, 9V/3A, 12V/3A, 15V/3A, 20V/3A
- When charging from USB PD charger, following current and voltage are applicable.
Imicro-50P : 5V/3A, 9V/3A, 12V/2.5A, 15V/2A, 20V/1.5A
Imicro-98P/Imicro-150P : 5V/3A, 9V/3A, 12V/3A, 15V/3A, 20V/3A
- The current capacity is displayed while charging with USB PD. At 100%, 5LEDs light up and then turn off.
- When charging another Imicro-50P / Imicro-98P / Imicro-150P from the battery via USB PD, it does not enable to determine which battery will be charged. This also appears when using a power bank. IDX highly recommend using PD charger when charging the battery.
- USB power turns off automatically after the USB cable is removed.
- Do not draw power from USB while charging via main connector as it may interrupt charging, cause a charger error, or damage the charger or battery.

V-Torch (LED Light)

- Embedded LED (on rear side) will turn on the light by pressing the capacity check button two times in a row. Ten seconds later, the LED will automatically turn off the light.
- It can also turn off manually by pressing the button two times in a row while lighting.
- Please do not stare into the light directly while lighting.

IB Setting

- The SB communication function can be activated by pressing and holding the Battery capacity display LEDs check button. By activating the SB mode, the battery data can be read by SMBus compliant equipment. Please refrain from using SB mode with equipment not compatible with SMBus protocol; Sudden power failure may occur due to communication failure.
- Configurable modes are
 - SB mode : The battery can communicate with SMBus compliant equipment.
 - IB mode : The battery can communicate with IDX's BMS compliant equipment.
 - The battery's default setting is in SB mode.
- To switch between SB mode and IB Mode:
 - Press the Battery capacity display LEDs check button for more than 10 seconds.
 - The top, middle, and bottom LEDs will briefly emit; the middle LED will turn off and the top and bottom (E and F) LEDs will remain lit for 3 seconds.
 - while the 2 LEDs (E and F) are emitting, release and press the button again.
 - When each mode is activated correctly, the LEDs will display 100%. If the LEDs do not display 100%, please restart the activation / deactivation process.
- SB mode and IB mode capacity display method
The LED patterns will indicate the current mode.
SB mode : the capacity display LEDs will light from "E" to "F"
IB mode : all of the capacity display LEDs will light simultaneously.
(When the remaining capacity is 100%, 5 positions of LEDs will light simultaneously.)

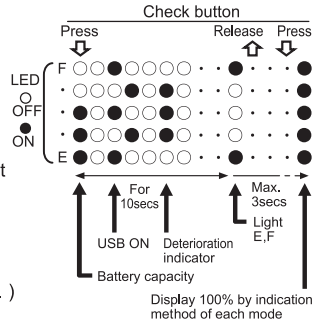

Battery Management System

This battery comes with digital function "Battery Management system(BMS)" and it enables you to check the remaining capacity information by using IDX charger that supports BMS, or your PC. For more information, please refer to the operation manuals for Battery Management System or IDX charger that supports BMS.

Cell Life Indicator (Life)

- LED lights also display the current full charge capacity compared to the capacity when new. (Deterioration ratio = Full charge capacity vs. Full charge capacity when new)
 - Press and hold the check button for more than 5 seconds. LEDs indicate the ratio for 2 seconds.
 - < ○●●●○ 3 lights on : Good condition, close to new >
 - < ○●●○● 2 lights on : Slightly degraded >
 - < ○●●○● 1 light on : Extremely degraded >
- Note : The degree of deterioration displayed is for guide only.

Life cycle

Life may vary depending on frequency of use, storage and operational temperature environment.
Life will be reduced if frequently used with high load applications.
Life is also reduced if stored in fully charged and/or empty conditions for extended periods.

Storing

- Store in cool and dry conditions.
- Do not store or leave in temperatures of 122°F (50°C) or above.
- For long-term storage, please store with about 30~40% of capacity (with 2 LEDs) and recommend for re-charging every five months.
- Deterioration of battery performance will be accelerated when the battery stored in a high ambient temperature and/or stored for long period without used.

Battery recycle

This Li-ion battery can be recycled. Please follow the regulations in your country or contact your local IDX office for further details.

Specifications

		Imicro-50P	Imicro-98P	Imicro-150P	
Cell chemistry		Li-ion			
Nominal voltage		DC14.54V			
Capacity		3.31Ah/49Wh *1	6.62Ah/97Wh *1	9.93Ah/145Wh *1	
Charge voltage		DC 16.8V			
Charge current (Main connector)		Max 1.655A	Max 3.31A	Max 4.965A	
D-Tap	Output voltage Battery through voltage				
	Maximum load 35W/2.0A(16.8V)~3.1A(11V)	Maximum load 100W/5.9A(16.8V)~9.0A(11V) *2			
USB PD	Input / Output : MAX30W (5V/3A,9V/3A,12V/2.5A, 15V/2A,20V/1.5A)		Input / Output : 60W (5V/3A,9V/3A,12V/3A,15V/3A,20V/3A)		
	Connector type : USB Type-C (Receptacles)				
USB OFF : 30 seconds after the USB cable is removed					
Main connector & D-Tap	Maximum discharge rate *3	≤77°F (25°C)	80W/4.7A (16.8V) 7.2A (11V)	145W/8.6A(16.8V) 13.1A (11V)	154W/9.1A (16.8V) 14.0A (11V)
		≤95°F (35°C)	65W/3.8A (16.8V) 5.9A (11V)	115W/6.8A (16.8V) 10.4A (11V)	136W/8.0A (16.8V) 12.3A (11V)
		≤113°F (45°C)	50W/2.9A (16.8V) 4.5A (11V)	80W/4.7A (16.8V) 7.2A (11V) ※2	105W/6.2A (16.8V) 9.5A (11V)
	Maximum discharge current *3	≤77°F (25°C)	8A	10A	13A
		≤95°F (35°C)	6A	8A	10A
		≤113°F (45°C)	4A	6A	8A
USB PD + Main connector & D-Tap	Maximum discharge current *4	≤77°F (25°C)	PD30W(20V/1.5A,15V/2A,12V/2.5A)+0W PD27W(9V/3A)+50W PD15W(5V/3A)+35W	PD60W(20V/3A)+0W PD45W(15V/3A)+65W PD36W(12V/3A)+100W PD27W(9V/3A)+100W PD15W(5V/3A)+115W	PD60W(20V/3A)+0W PD45W(15V/3A)+109W PD36W(12V/3A)+118W PD27W(9V/3A)+127W PD15W(5V/3A)+139W
		≤95°F (35°C)	PD27W(9V/3A)+35W PD15W(5V/3A)+25W	PD45W(15V/3A)+45W PD36W(12V/3A)+70W PD27W(9V/3A)+70W PD15W(5V/3A)+80W	PD45W(15V/3A)+80W PD36W(12V/3A)+100W PD27W(9V/3A)+100W PD15W(5V/3A)+110W
		≤113°F (45°C)	PD27W(9V/3A)+0W PD15W(5V/3A)+12W	PD45W(15V/3A)+20W PD36W(12V/3A)+25W PD27W(9V/3A)+35W PD15W(5V/3A)+40W	PD45W(15V/3A)+35W PD36W(12V/3A)+50W PD27W(9V/3A)+55W PD15W(5V/3A)+65W
End voltage		11V			
Battery protection circuit		Over-charge, Over-discharge, Over-current, Thermal protection			
Ambient temperature		Charge 32~104°F (0~40°C) (50~86°F (10~30°C) recommended)			
		Discharge -4~113°F (-20~45°C) (50~104°F (10~40°C) recommended)			
		Storage -4~122°F (-20~50°C) (less than 1 month)			
Dimensions	mm	73(W)×100(H)×39.5(D)	73(W)×100(H)×55(D)	73(W)×100(H)×71.25(D)	
	Inches	2.87(W)×3.93(H)×1.55(D)	2.87(W)×3.93(H)×2.16(D)	2.87(W)×3.93(H)×2.8(D)	
Weight	g	approx, 380	approx, 580	approx, 810	
	lbs	approx, 0.83	approx, 1.27	approx, 1.78	

*1. Measured capacity of battery is a minimum rating at 68°F(20°C).

*2. The maximum power output of the Imicro-98P is 80W at the temperature of 95~113°F (35~45°C).

*3. Maximum load is the sum of D-Tap and Camera loads.

*4. Maximum load is the sum of D-Tap, USB PD and Camera loads.

Li-ion Battery Air transport Compliance

The Air transport regulations for the lithium-ion batteries will be revised regularly, so please check our website before transporting the battery.
(<http://idxtek.com/lithium-ion-transportation/>)

Compensation for recorded content

Recorded content cannot be compensated for if recording or playback is disabled due to a malfunction of the battery pack or other devices.

* Design and specifications are subject to change without notice.

* USB Type-C® and USB-C® are trademarks or registered trademark of USB Implementers Forum companies.

Manufacturer : **IDX Company, Ltd.** 6-28-11 Shukugawara, Tama-ku, Kawasaki-shi, Kanagawa-ken, 214-0021 Japan

Tel : +81-44-850-8801 Fax : +81-44-850-8838 URL : <https://www.idx.tv/> E-mail : idx.japan@idx.tv

Importer for EU : **IDX Technology Europe, Ltd.** 391 Edinburgh Avenue, Slough Industrial Estate, Slough, SL1 4UF, England

Tel : +44-1753-547692 Fax : +44-1753-546660 URL : <http://www.idx-europe.co.uk/> E-mail : idx.europe@idx.tv

Importer for USA : **IDX System Technology, Inc.** 2377 Crenshaw Blvd, Suite 154, Torrance CA 90501 USA

Tel : +1-310-328-2850 Fax : +1-310-328-8202 URL : <http://www.idxtek.com/> E-mail : idx.usa@idx.tv



202309

BLMK230079-1